

SRT364G



FEATURES

- 4 dual-stacked burners plus 15,000 Btu infrared griddle
- Dual-stacked burners go from 20,000 Btu down to a mere breath of flame
- Continuous cast-iron grates for easy movement of pots and pans
- Heavy-gauge stainless steel
- Rigorously tested in our U.S. manufacturing facilities for decades of use
- Exceptional 24/7 support from our Customer Care team in Madison
- Signature red infinite control knobs
- Spark ignition system re-ignites if flame goes out

ACCESSORIES

- 11" Cutting Board
- Stainless steel, brass or chrome bezels
- High altitude conversion kit
- Cast iron S-grates and wok grate
- Signature red, black or stainless steel control knobs
- 5" and 10" stainless steel risers, and 20" riser with shelf

Accessories available through an authorized Sub-Zero dealer.
For local dealer information, visit subzero-wolf.com/locator.



KNOB OPTIONS



TOP CONFIGURATION

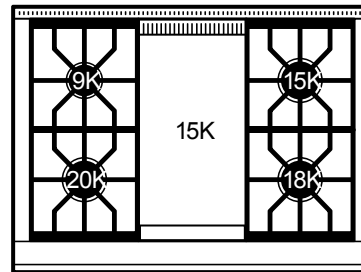

RANGETOP SPECIFICATIONS

- 1 - 9,200 Btu Burner
- 1 - 15,000 Btu Burner
- 1 - 18,000 Btu Burner
- 1 - 20,000 Btu Burner
- 1 - 15,000 Btu (13,000 Btu LP) Griddle

PRODUCT SPECIFICATIONS

Model	SRT364G
Dimensions	35 7/8"W x 8 1/2"H x 28 1/2"D
Weight	220 lbs
Electrical Supply	110/120 VAC, 60 Hz
Electrical Service	15 amp dedicated circuit
Gas Supply	3/4" rigid pipe
Gas Inlet	1/2" NPT female
Receptacle	3-prong grounding-type

ELECTRICAL

GAS

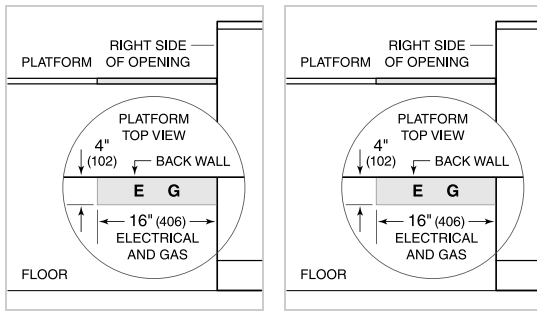

DIMENSIONS

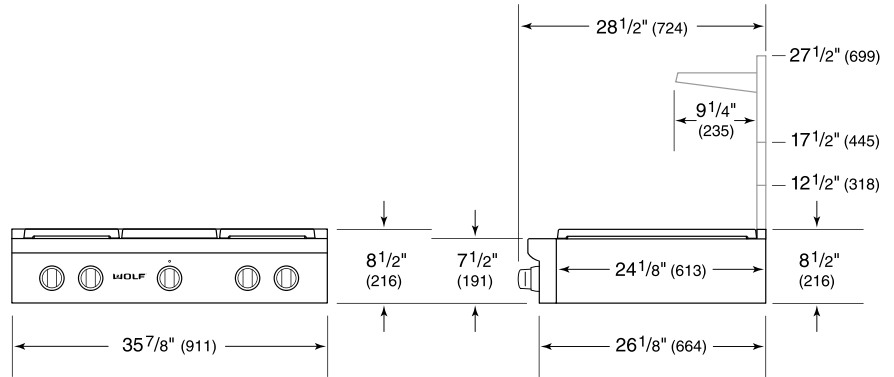

STANDARD INSTALLATION

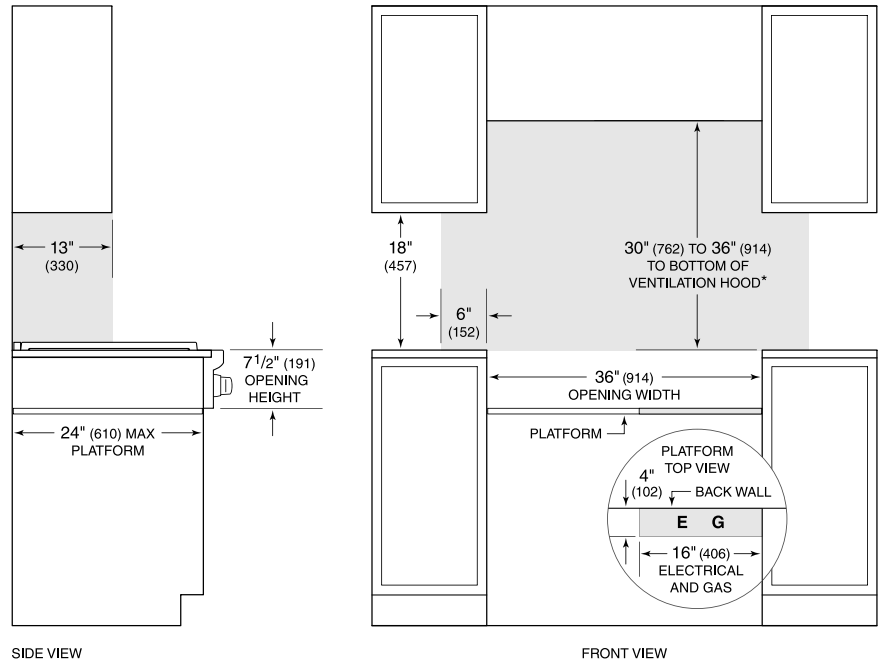

SIDE VIEW

FRONT VIEW

*Without ventilation hood, 36" (914) minimum clearance countertop to combustible materials, 44" (118) for charbroiler.
 NOTE: Shaded area above countertop indicates minimum clearance to combustible surfaces, combustible materials cannot be located within this area.
 Electrical and gas supply located through bottom of platform.
 For island installation, 12" (305) minimum clearance back of range to combustible rear wall above countertop.