



## Convection Steam Oven

Delivering precise control is easy with a variety of steam, convection, and combination steam and convection cooking options. Unique technology senses the amount, size, and shape of food once an automatic mode has been selected. While cooking, it monitors the time, temperature, and environment, eliminating all guesswork in the kitchen. Virtually any dish prepared in a conventional oven, range or microwave can also be prepared in the Wolf convection steam oven.



Model CSO24.

### FEATURES

- Stainless steel with tubular handle.
- Can be installed in a standard or flush inset application.
- Stainless steel trim to match L series and E series ovens.
- Convection with twelve cooking modes: steam, reheat, auto steam bake, convection, convection humid, convection steam, Wolf gourmet, slow roast, recipes, my recipes, keep warm, descale and cleanse.
- Four-level rack guides with two adjustable oven racks.
- One perforated 17<sup>3</sup>/<sub>4</sub>" x 1" x 15" stainless steel pan.
- One solid 17<sup>3</sup>/<sub>4</sub>" x 1" x 15" stainless steel pan.
- Large viewing window and halogen interior lighting.
- Temperature probe.
- Water tank with lid.
- Recipes mode.
- Delayed start feature and descaling program.
- Agency certified for US and Canada.

### ACCESSORIES

- 30" (762) L and E series stainless steel trim—framed and unframed.
- Perforated stainless steel pans—12<sup>3</sup>/<sub>4</sub>" x 1<sup>1</sup>/<sub>2</sub>" x 7" and 12<sup>3</sup>/<sub>4</sub>" x 2<sup>1</sup>/<sub>2</sub>" x 7".
- Solid stainless steel pans—12<sup>3</sup>/<sub>4</sub>" x 1<sup>1</sup>/<sub>2</sub>" x 7" and 12<sup>3</sup>/<sub>4</sub>" x 1<sup>1</sup>/<sub>4</sub>" x 14".
- Oven rack.
- Descaling solution.

*Accessories are available through your authorized Wolf dealer. For local dealer information, visit the find a showroom section of our website, [wolfappliance.com](http://wolfappliance.com).*

### BENEFITS OF CONVECTION STEAM

- Moistness and flavor are retained so no additional oil, basting or sauces are necessary.
- Vitamins, texture, shape, size and color are preserved.
- Risks of overcooking are reduced and messy boilovers eliminated.
- Breads, bagels, bakery and pastry can be proofed, baked and crisped with steam.
- Meats defrost gently and evenly without any hot spots.
- In Wolf gourmet mode, a sensor automatically adjusts cooking time to the type and amount of food being cooked, preventing under- or overcooking.
- Smart timer functions are like an extra pair of hands, cooking food that's ready to serve when you need it—even when you're not in the kitchen to start and stop the oven.



Model CSO24 interior.



## Convection Steam Oven

### OVERALL DIMENSIONS

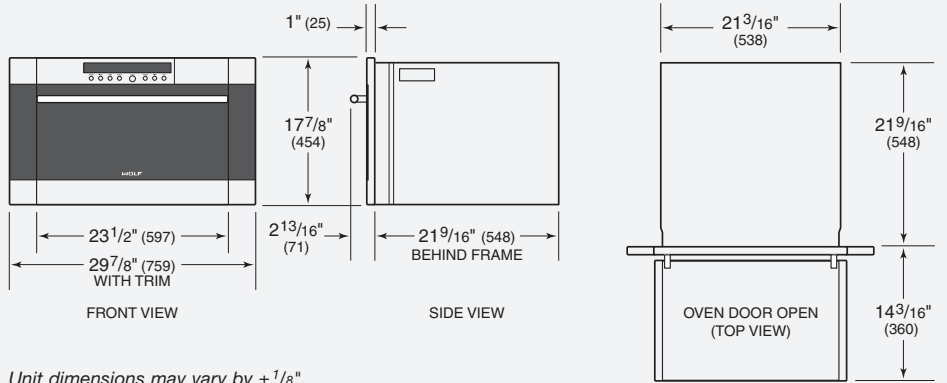

Unit dimensions may vary by  $\pm 1/8"$ .

### SPECIFICATIONS

|                             |                                       |
|-----------------------------|---------------------------------------|
| Overall Width               | 23 1/2"                               |
| Overall Width with 30" Trim | 29 7/8"                               |
| Overall Height              | 17 7/8"                               |
| Overall Depth               | 22 9/16"                              |
| Interior Capacity           | 1.8 cu ft                             |
| Interior Dimensions         | 17 7/8" W x 11" H x 15 3/4" D         |
| Power                       | 3800 W                                |
| Electrical Requirements     | 240/208 V AC<br>60 Hz, 20 amp circuit |
| Power Cord                  | 6' cord with grounded plug            |
| Shipping Weight             | 80 lbs                                |

### INSTALLATION SPECIFICATIONS

#### Standard Installation

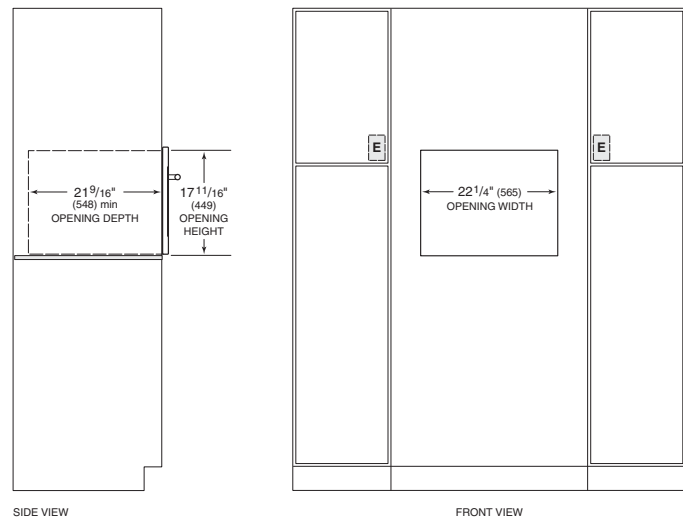

NOTES: Minimum base support 100 lbs (45 kg).  
Electrical supply must be located in adjacent cabinet within 3' (0.9 m) of opening.  
Dashed line represents profile of unit.

#### Flush Inset Installation

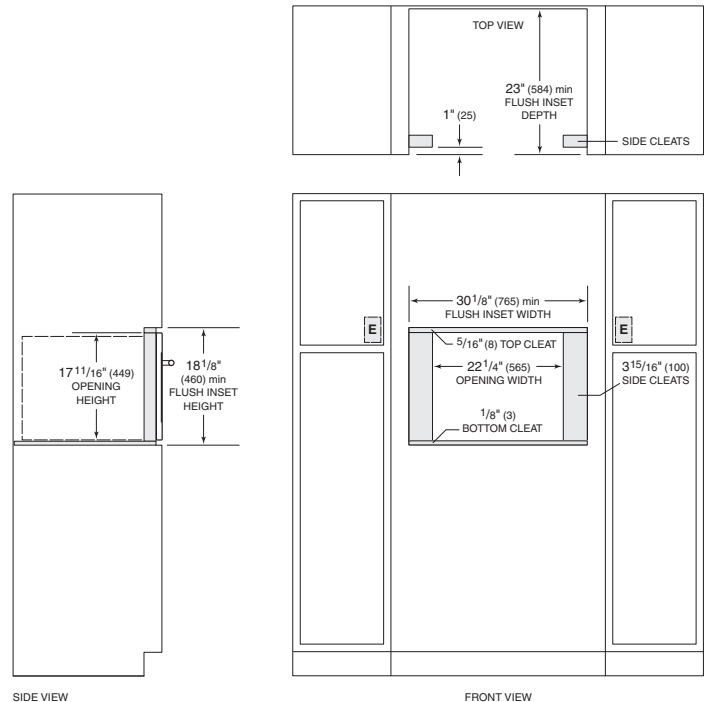

NOTES: Minimum base support 100 lbs (45 kg).  
Electrical supply must be located in adjacent cabinet within 3' (0.9 m) of opening.  
Cleats may be visible and should be finished to match cabinetry.  
Dashed line represents profile of unit.

### INSTALLATION NOTES

Complete installation specifications can be found on our website, [wolfappliance.com](http://wolfappliance.com).

Dimensions in parentheses are in millimeters unless otherwise specified.